

DESIGNING FOR PHYSICAL ACTIVITY

EXPLORING OPPORTUNITIES TO ENCOURAGE PHYSICAL ACTIVITY IN EVERYDAY LIFE

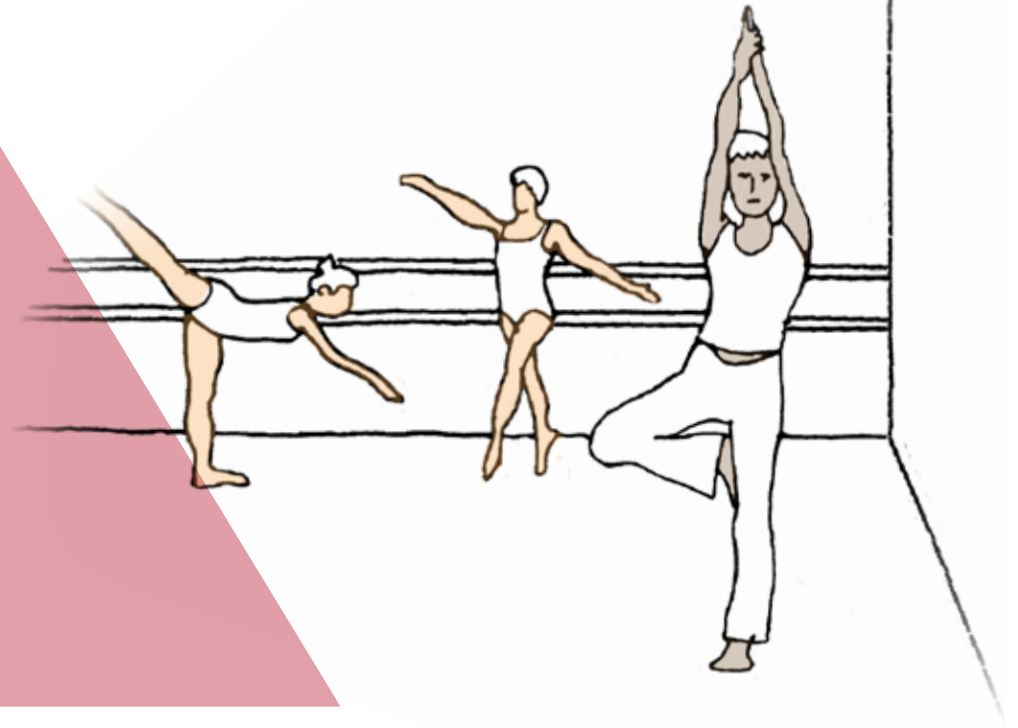

INDOOR SPACES



The Government's 'Sporting Future' strategy was published in December 2015 with a clear focus on the benefits that sport can bring to people and to society, built around a simple set of outcomes: physical wellbeing, mental wellbeing, individual development, social and community development and economic development.

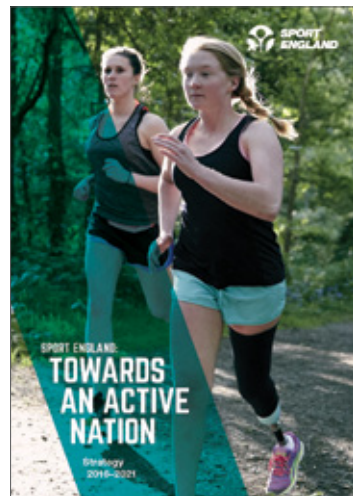
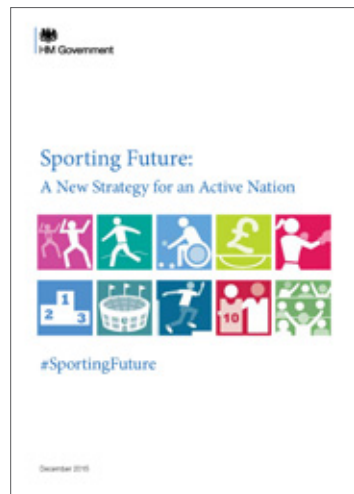

Sport England's strategy 'Towards an Active Nation' was published in May 2016 with a vision that everyone, regardless of age, background or level of ability, can engage in physical activity.

FOREWORD

THE CREATION OF EASILY ACCESSIBLE SPACES THAT INSPIRE AND ENCOURAGE PEOPLE TO BE MORE PHYSICALLY ACTIVE AS PART OF THEIR EVERYDAY LIVES IS A CENTRAL CONSIDERATION

“ *Creating more opportunities to be physically active means thinking about many prompts and cues that enable positive changes in our behaviour. An active environment is one which responds to community needs and aspirations and provides the conditions and opportunities for people to be more active in their everyday lives. Active environments require a more coordinated and holistic approach to the design and operation of our surroundings from streets, neighbourhoods and public open spaces to the policies, standards and planning of the infrastructure of where we live and work.* ”

Charles Johnston

Executive Director of Property, Sport England

1.0	4
Introduction	
Active Design	
Physical activity and sport	
Indoor spaces overview	
2.0	6
Considerations	
Community needs	
Local opportunities	
Suitable indoor space	
Overall feel and attractiveness of the facility	
3.0	9
Space Requirements	
Range of activities	
Typical dimensions	
Smaller or irregularly-sized spaces	
Space per person	
Creating comfortable and safe spaces	
Risk assessment	
4.0	17
Examples	
Example 1: Activity space	
Example 2: Village hall	
Example 3: Small community recreation centre	

CONTENTS

SEE OTHER GUIDANCE ON DESIGNING FOR PHYSICAL ACTIVITY COVERING:

- **ACTIVITY HUBS**
- **BUDGET COSTS**
- **COVERED OUTDOOR SPACES**
- **OUTDOOR SPACES**
- **ROUTES AND WAYFINDING**
- **OTHER TOPICS**

THESE AND THE ASSOCIATED ACTIVE DESIGN GENERAL PRINCIPLES AND CASE STUDIES ARE AVAILABLE AT:

<https://www.sportengland.org/facilities-planning/active-design/>

1.0 INTRODUCTION

ACTIVE DESIGN

ACTIVE DESIGN IS ROOTED IN SPORT ENGLAND'S AIMS AND OBJECTIVES TO PROMOTE THE ROLE OF SPORT AND PHYSICAL ACTIVITY IN CREATING HEALTHY AND SUSTAINABLE COMMUNITIES.

ACTIVE DESIGN IS SUPPORTED BY PUBLIC HEALTH ENGLAND AND IS PART OF OUR COLLABORATIVE ACTION TO PROMOTE THE PRINCIPLES SET OUT IN PUBLIC HEALTH ENGLAND'S 'EVERYBODY ACTIVE, EVERY DAY', TO CREATE ACTIVE ENVIRONMENTS THAT MAKE PHYSICAL ACTIVITY THE EASIEST AND MOST PRACTICAL OPTION IN EVERYDAY LIFE.

<https://www.sportengland.org/facilities-planning/active-design/>

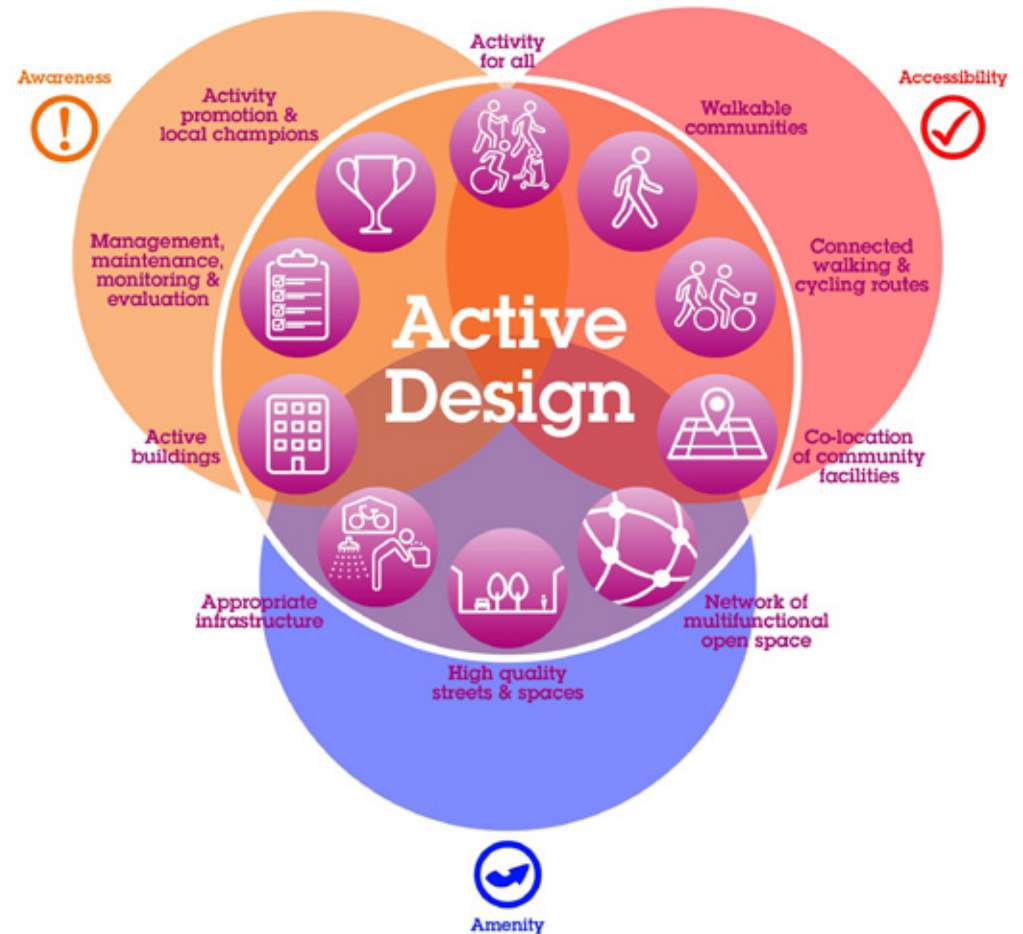

The ten principles of Active Design - achieving as many of these as possible within an Active Environment will optimise opportunities for active and healthy lifestyles

PHYSICAL ACTIVITY AND SPORT

The term 'physical activity' can cover a wide range of informal, casual and recreational pursuits that maintain or enhance fitness, health and overall wellbeing. The term 'sport' is usually associated with more formal training or competition.

For all parts of the spectrum, easily accessed spaces that inspire and enable people of all ages to be physically active as they wish are a valuable community asset. Innovative approaches are advocated that remove barriers to participation and are proportionate and appropriate to customer needs.

Where there is a clear need for formal sports spaces, then the relevant prevailing guidance from national governing bodies of sport (NGBs), Sport England, Department for Education or Education Funding Agency should be followed. However, a distinction should be made between the formal requirements of spaces for sport and more informal spaces for physical activity, albeit that the underlying principles of any relevant prevailing guidance should not be disregarded.

Local context, potential users and site specific risk assessments are all important considerations during the design and briefing stages of a project. For further advice on good practice, visit the Sport England, The Royal Society for the Prevention of Accidents (RoSPA) and the Health and Safety Executive (HSE) websites.

INDOOR SPACES OVERVIEW

This document considers the use of small indoor spaces for physical activity within a local community setting whether urban, suburban or rural. It promotes the development of opportunities in both new build projects and the re-use or conversion of existing facilities.

Spaces for physical activity can be created in a wide range of buildings from schools, sports clubs and clubhouses to village and community halls. Although most sports require minimum dimensions and other key requirements, almost any space can be used for some form of physical activity.

The guide looks at a range of activities that could be suitable for small spaces and also courts that could be accommodated for more formal sports. It discusses the need for a proportionate approach to design where space may be limited but subject to risk assessments, may still allow meaningful and enjoyable recreational activities to take place depending on the number of participants and the specific spatial characteristics.

All facilities should be designed to be attractive, welcoming and have customer appeal. However, equally important as the space itself, research has highlighted that 'convenience' factors such as proximity to home or work, ease of booking and accessibility are also critical to encouraging participation.

MANY SMALLER INDOOR SPACES CAN BE ADAPTED AND CONFIGURED TO ENCOURAGE AND SUSTAIN PHYSICAL ACTIVITY. THESE SPACES COULD BE CO-LOCATED ON EDUCATION SITES, BE PART OF A SPORTS CLUB, COMMUNITY HALL OR PLACE OF WORSHIP.

THIS DOCUMENT CONSIDERS SOME OF THE DESIGN AND OPERATIONAL PRINCIPLES THAT WILL CREATE APPROPRIATE, WELCOMING AND FUNCTIONAL INDOOR SPACES.

SPECIFIC LOCAL REQUIREMENTS FOR PHYSICAL ACTIVITY SHOULD BE MATCHED WITH EXISTING INDOOR SPACES AND/ OR THE CREATION OF NEW SPACES THAT ARE PROPORTIONATE TO NEEDS

2.0 CONSIDERATIONS

COMMUNITY NEEDS

Community consultation, whether in a small rural village or inner city neighbourhood, can often result in a comprehensive 'wish list' for new facilities that are disproportionate and unrealistic for a local community to achieve. Nevertheless, there are likely to be many opportunities to be more active that can be encouraged through the adaptation of existing, local provision or by creating appropriately-scaled new facilities. These can create a destination or hub for the community and the more multi-functional, the greater the appeal to a wider community. For many people, the general health and social benefits associated with being physically active have greater appeal than taking part in more formal sports activities.



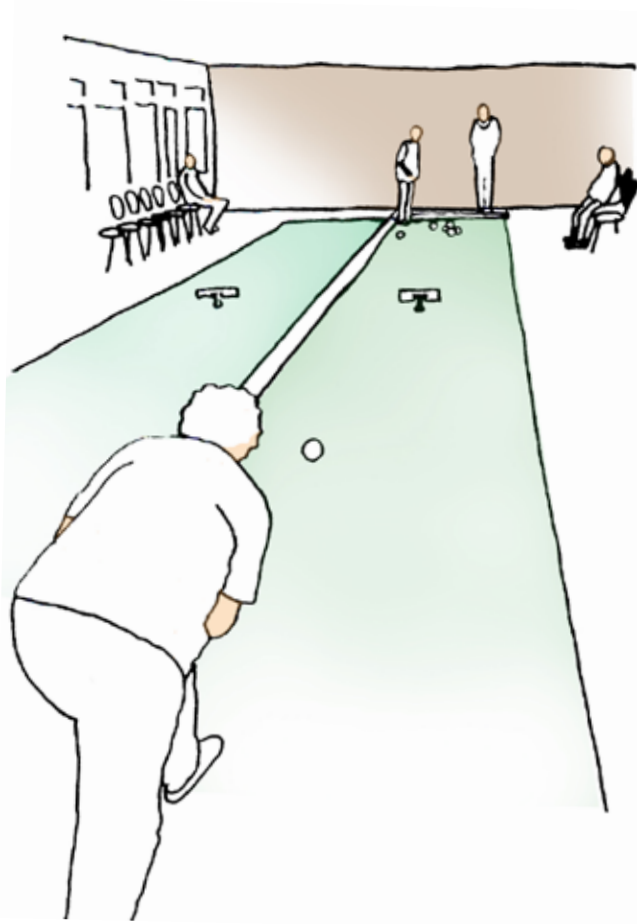

LOCAL OPPORTUNITIES

The development of local facilities is an ideal way to encourage initiatives within a community that can have widespread benefits. Providing improved or new physical activity spaces for community use can open up opportunities previously unattainable. For example:

- Historic buildings that have been abandoned may be brought back into use
- Increased footfall in good-quality but under-used buildings can improve financial viability and sustainability
- New well-designed and equipped buildings can replace poor-quality provision that has outlasted its useful life
- Extra rooms and facilities can be added to buildings that have been 'bursting at the seams' under intensive use.

With some careful thought, many public buildings may be suitable destinations for a wide variety of physical activity and it is also worth considering how any available outdoor space and connecting routes can complement and enable this broader use. This could include developing outdoor spaces for improved access or car and cycle parking and connected networks of footpaths and cycle routes to encourage active communities.

A good starting point is to consider the findings of community consultation in conjunction with mapping anywhere local people gather, from places of worship to social meeting venues. Then consider how these facilities could be part of an overall plan for meeting wider needs to create more effective community resources. In other words, making the very best of what already exists with adaptations to give spaces a new lease of life, or making the best use of any new facilities.

Below are example considerations:

- How people move around the local area – walking and cycling or using public transport and driving?
- Location of any walking and cycling routes between houses and local shops, schools and community buildings?
- Co-location of proposed indoor facilities with existing and new pathways and cycle routes 'connecting' communities with other outdoor spaces and activities?
- Potential for compromise if indoor facilities should be dispersed across several venues in or beyond the locality or be in one facility combining physical activity with social, arts, drama, and broader community use?
- Adaptations, extensions and upgrades of existing community spaces to increase standards and activities?
- Additions of new ancillary accommodation, such as secure storage, to 'free up' activity spaces?
- Existing spaces in schools 'opened up' for more community use?



SUITABLE INDOOR SPACE

The potential of smaller spaces to accommodate indoor physical activities will depend on the particular characteristics of the space in question.

Below are points to consider:

- Spatial requirements – proportionate and appropriate for the use. Start with the actual dimensions of the area available and consider what can be done
- Internal finishes – avoiding projections into the activity space from wall nibs, columns, wall-mounted kit, or doors opening into the space
- Comfort - heating, lighting, and ventilation
- Suitable floor surface - particularly important for physical activity.

These are covered in more detail in Section 3.0 Space Requirements with examples of activities and sizes that can be accommodated.

OVERALL FEEL AND ATTRACTIVENESS OF THE FACILITY

Achieving an attractive overall ambience to both the inside and outside of the building should be encouraged. First impressions can be very important for new users and the appearance from the road, easy parking, clear signage and a welcoming entrance should all be carefully considered. A facility that provides good customer appeal is more likely to retain existing members as well as attracting new ones.

CONSIDER A WIDE RANGE OF POTENTIAL ACTIVITIES THAT CAN BE ACCOMMODATED IN A SPACE



3.0

SPACE REQUIREMENTS

RANGE OF ACTIVITIES

Almost any small space can be used for some form of physical activity. An individual can install a fitness training machine in their garage or a spare room and a small group can set up a regular keep fit class in a room in a local community building.

Many of the traditional English games, pastimes or sports are said to have originated in small spaces in schools, places of worship or social meeting places that were in use at the time. It was only later that they were codified with official rules and court dimensions when they became more popular. Even now, some communities enjoy traditional physical activity events that are unique to a particular locality.



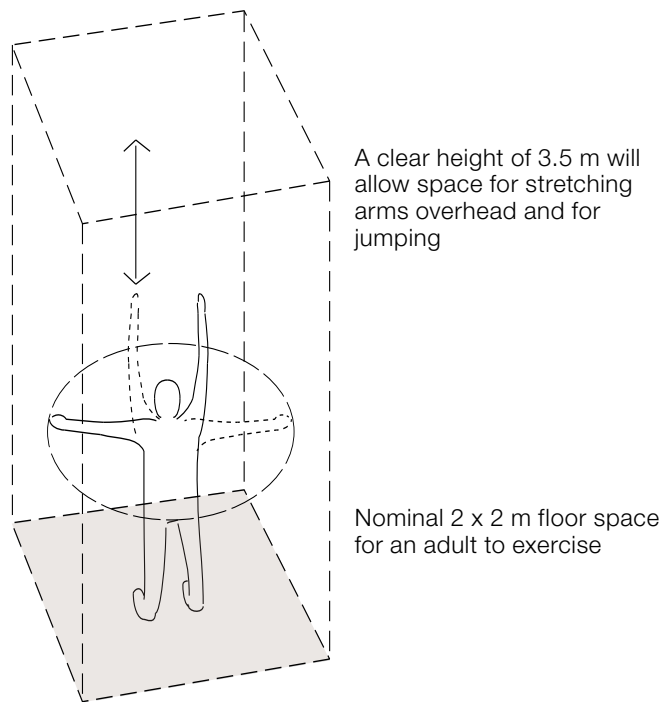

Indicative space allowance

Indicative average heights:

- Male 1.78 m
- Female 1.63 m

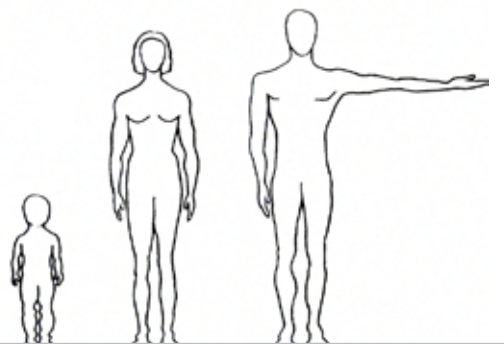

Average human dimensions

TYPICAL DIMENSIONS

Many types of physical activity can be accommodated in small spaces and some examples are included in the table on page 11 showing activities and indicative sizes. Much will depend on the actual usable floor area, the clear height available, and the general feel and characteristics of the space concerned. The numbers, age and gender of users occupying the space at a particular time should also be considered. Any associated risks should be evaluated - see section on 'Risk assessment' on page 15.

SMALLER OR IRREGULARLY-SIZED SPACES

At a recreational level, activities that are played on a court across a net may allow scope for dimensional reductions to suit the actual space concerned. That is to say, some activities could take place on a smaller space than would normally be recommended. For example, the length or width of a pickleball court could be reduced to suit a particular space available. Alternatively, individuals could agree to play an informal or modified version of activities such as badminton or tennis to suit their particular level of skills, physical abilities and space available.

SPACE PER PERSON

When considering the use of a small space for physical activity, it can be useful, as an approximate guide to potential occupancy levels, to base accommodation allowances on an indicative minimum space per person. For example, in a group stretching or exercise class, an adult male with arms stretched out can require a zone of approximately 2 x 2 m (4 m²) to avoid touching the next person. A clear height of 3.5 m will allow space for stretching arms overhead and for jumping. If the session requires a lead person, then additional space is required at the front.

There may also be commercial pressures to have a minimum number of participants for financial viability and therefore specific requirements for the proposed activities are important considerations to identify.

See Sport England Design Guidance Note 'Fitness and Exercise Studios':

<https://www.sportengland.org/facilities-planning/design-and-cost-guidance/other-design-guidance/>

DESIGNING FOR PHYSICAL ACTIVITY - INDOOR SPACES

REV 001 - APRIL 2019

The schedule below outlines some of the potential physical activities that can be accommodated in a range of example indicative spaces.

Activity	Accommodation ¹	Example activity space indicative sizes								
		5 m x 5 m x 3.5 m high	4 m x 8 m x 3.5 m high	9 m x 9 m x 3.5 m high	10 m x 10 m x 3.5 m high	10 m x 14 m x 4.5 m high	12 m x 15 m x 4.5 m high	10 m x 18 m x 6.7 m high	17 m x 18 m x 6.7 m high	27 m x 18 m x 7.5 m high
Martial arts / self-defence	U	●	●	●	●	●	●	●	●	●
Aerobics / Medau movement	U	●	●	●	●	●	●	●	●	●
Folk dancing	U	●	●	●	●	●	●	●	●	●
Keep fit	U	●	●	●	●	●	●	●	●	●
Boxercise	U	●	●	●	●	●	●	●	●	●
Yoga or Pilates	U	●	●	●	●	●	●	●	●	●
Tai Chi	U	●	●	●	●	●	●	●	●	●
Kabaddi	U	●	●	●	●	●	●	●	●	●
Dance and movement	U	●	●	●	●	●	●	●	●	●
Circuit training	U	●	●	●	●	●	●	●	●	●
Playgroup	U	●	●	●	●	●	●	●	●	●
Soft archery	U	●	●	●	●	●	●	●	●	●
Armchair aerobics	U	●	●	●	●	●	●	●	●	●
Courts (C) / Rinks (R) / Tables (T)										
Table tennis	T	-	1	2	2	3	3	4	8	12
Boccia	C	-	-	-	-	1	1	1	3	6
Carpet bowls	R	-	-	-	-	3	4	3	6	10
Short mat bowls	R	-	-	-	-	4	4	4	7	11
Fencing	C	-	-	-	-	-	-	2	4	7
Goalball	C	-	-	-	-	-	-	1	1	2
Badminton	C	-	-	-	-	-	-	1	2	3
Mini tennis	C	-	-	-	-	-	-	1	2	3
Pickleball	C	-	-	-	-	-	-	1	2	3
Sitting volleyball	C	-	-	-	-	-	-	-	1	2
Volleyball	C	-	-	-	-	-	-	-	-	1

¹ Numbers are approximate and subject to site specific risk assessments and NGB requirements

CREATING COMFORTABLE AND SAFE SPACES

Consider user needs for each type of activity that may be accommodated, and spatial requirements to achieve a free open space. For example:

- Can people access it easily?
- Is it warm enough?
- Is the flooring suitable for physical activity?
- Does the space present any risks for physical activity?
- Is the lighting bright enough?
- Are there projections such as columns, piers, window reveals/cills, or other features which extend into the activity area? Such projections should ideally be avoided
- Are radiators and fire extinguishers located within recesses and protected from potential damage due to the activities?
- Is there a safety margin around the activity area?
- Are there any loose items occupying the perimeter of the space such as activity equipment not in use? If so, remove and store elsewhere e.g. to a dedicated adjacent equipment store or consider storing items seldomly used remotely - see following section on 'Flexibility and storage'
- Are there changes in level which may affect play or create a trip hazard?

SEE THE ASSOCIATION FOR PHYSICAL EDUCATION (AFPE) FOR INFORMATION ON STANDARDS AND SAFE PRACTICE

<http://www.afpe.org.uk/>

RESISTANCE TO DAMAGE

Consider the types of equipment that will be used for the intended activities and the wear and tear that should be expected to floors and potentially also to walls, ceilings, doors and windows. Different activities will create different demands on the structure. For example, the use of free weights on a suspended timber floor and the potential need to strengthen the respective area for this purpose or else, deem the activity to be unsuitable for the space.

FLEXIBILITY AND STORAGE

Lack of storage space for equipment is a common problem in many indoor activity spaces and sporting items can also be attractive to thieves. Items should be stored or removed at the end of an activity as much as possible. Storage areas should be convenient, safe and easy to use (i.e. the 10-minute test) and should not create obstructions in and around the activity and circulation routes. Any items stored overhead should not be prone to collapse or create other safety, security or fire risk issues.

Purpose-built storage trolleys, supplied by chair, table or sports equipment manufacturers can enable easier handling and maximise storage space efficiency. Prioritising the use of equipment will also enable further efficiencies in terms of creating short, medium and long-term storage compartments for easier access and convenience.



Example equipment storage requirements for a 10 x 10 m activity space

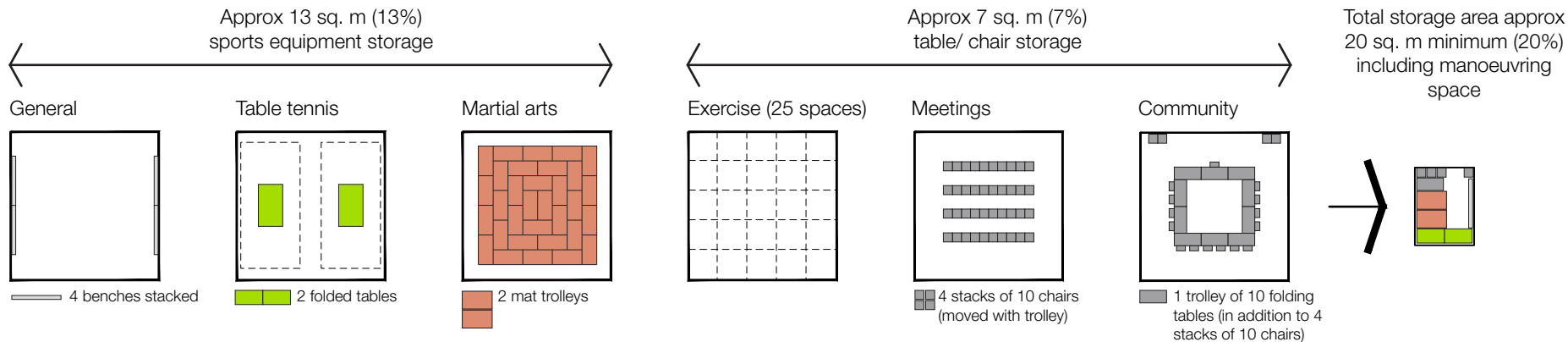

Example equipment storage requirements for a 10 x 18 m activity space

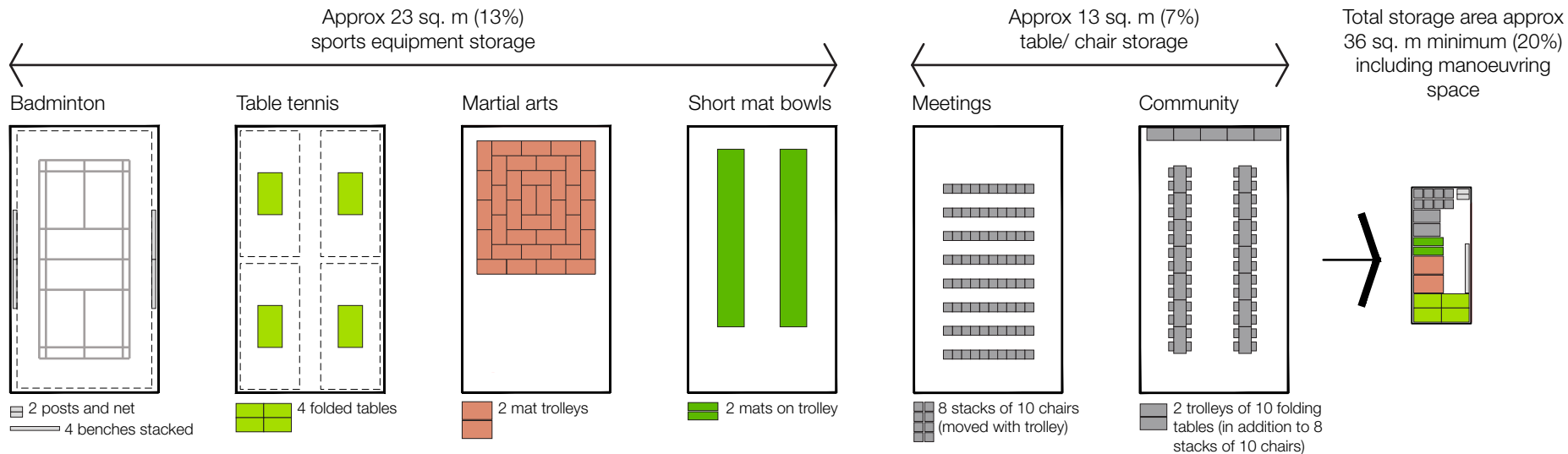

An adjacent storage area will allow equipment to be easily accessed before and after a particular physical activity. Storage of equipment in the activity space can create safety issues and should generally be avoided. See page 15.

The size of the equipment store will vary with the size of the space, the equipment and the particular programme of activities that is followed. The diagram above suggests a minimum of 20% of the activity space floor area.

FLOORS

Most purpose-built multi-use activity facilities will have a specialist multi-activity floor finish with a prescribed range of performance characteristics. For example, the degree of grip / slip resistance and force reduction to give a degree of softness underfoot are important considerations for many activities. This is particularly the case for club and competition levels of play where players may be training for long periods of time.

However, in a local situation where a small activity space may have a more general-purpose solid floor, the use of various types of sports shoes can help compensate for any shortcomings in the surface. For example, tennis shoes that are designed to be used on outdoor 'hard' courts can give a degree of cushioning and grip.

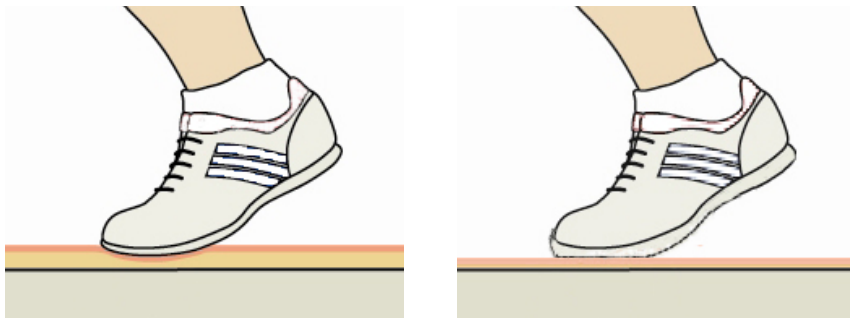

Ideally, a multi-activity flooring system should be provided that provides the performance characteristics (slip resistance, deflection and energy absorption) to BSEN 14904 : 2006

For some activities, appropriate sports shoes can compensate for deficiencies in deflection and energy absorption qualities of a solid floor

Generally, floors should be of the same type throughout the activity space, smooth and flat (e.g. no lifting tiles, splinters or sharp edges), warm, and ideally with some shock absorption.

Maintaining the floor in a clean and dust-free condition is important and will be more easily achieved when there is adequate storage provision and cleaning equipment to allow the space to be kept free and open for maximum access.

WALLS / DOORS / WINDOWS

There should be no obstacles and obstructions to the principal activity area and the safety margin around it. Ideally, walls should be flush faced to reduce risk of injury should a person make impact. Where necessary to mitigate risks, consider the use of padding, remove unnecessary equipment (which can be placed in a locker or storage), remove fittings and fixtures that render a space unusable (base or wall cupboards, cabinets which could be relocated, redundant or worn-out equipment).

Also consider door swings and how they can be changed or managed to avoid hazards to users.

Views into the activity space may not be desirable but blinds can provide adequate privacy while still allowing views out when wanted - a visual link to the outside may be important to customers and a 'shop window' for the activities on offer.

CEILING AND FITTINGS

The height of ceilings and overhead fittings is important for activities such as aerobics where people might jump with arms stretched - see page 10. The robustness of overhead light fittings and ceiling materials should also be considered for activities e.g. involving balls or shuttlecocks.

LIGHTING

There are recommended lighting levels for spaces specifically designed for NGB activities with most starting from 200-300 lux of illuminance for community levels of play. This would also be suitable for the majority of indoor physical activities and be in line with the general standard for multi-use spaces.

See Sport England's 'Artificial Sports Lighting' Design Guidance Note:

<https://www.sportengland.org/facilities-planning/design-and-cost-guidance/artificial-sports-facilities/>

RISK ASSESSMENT

For physical activity in a new or existing facility, some level of risk assessment is recommended and will be a legal requirement in some situations. For examples, the designer will have a responsibility for a new facility and the employer a responsibility where there are more than five employees. It need not be an overly-bureaucratic process but simply a common sense assessment of any hazards that might exist and the ways that they can be mitigated. It could be an easily understood visual check list that players and coaches can agree with the facility operator.

All physical activities that involve movement and levels of competition can be said to have some inherent risk for the participants. For example, people may accidentally trip or fall, collide with other players or fixed equipment or be hit by a ball. Generally, these are accepted as part of the game, subject to conformity with the rules of play and recommended court dimensions and floor finishes etc. However, a risk assessment should focus on all factors relating to the spaces in which the activity takes place such as:

- Slippery floor due to a build up of dust or water leak from the roof
- Projecting wall fittings that create a hazard
- Poor levels of lighting
- Equipment left in or near by the activity space.

Play will often be organised in clubs or activity groups and involve a level of training, instruction and an agreed level of supervision. This will encourage a common sense approach that includes an awareness of safety issues and a culture of avoiding accidents.

There are standard dimensions for playing areas (courts) that are usually fixed but the perimeter 'run-off' area around the court can vary with the level of play and age of participants. Generally, more 'run-off' space is recommended as the standard of competition increases to reflect a potentially more intensive and vigorous level of play.

Some NGBs recognise that for teaching and/ or community/ recreational levels of play, the space requirements for the court and/ or run offs can be reduced to suit a particular situation. Nevertheless, a risk assessment can be a practical way of demonstrating the arrangements are both safe and acceptable to all parties.

It is important that facility providers establish who is responsible for assessing risks and communicating to the users of activity spaces.

For further information, see:

<https://www.sportenglandclubmatters.com/club-planning/governance/managing-risk-2/risk-assessment/>

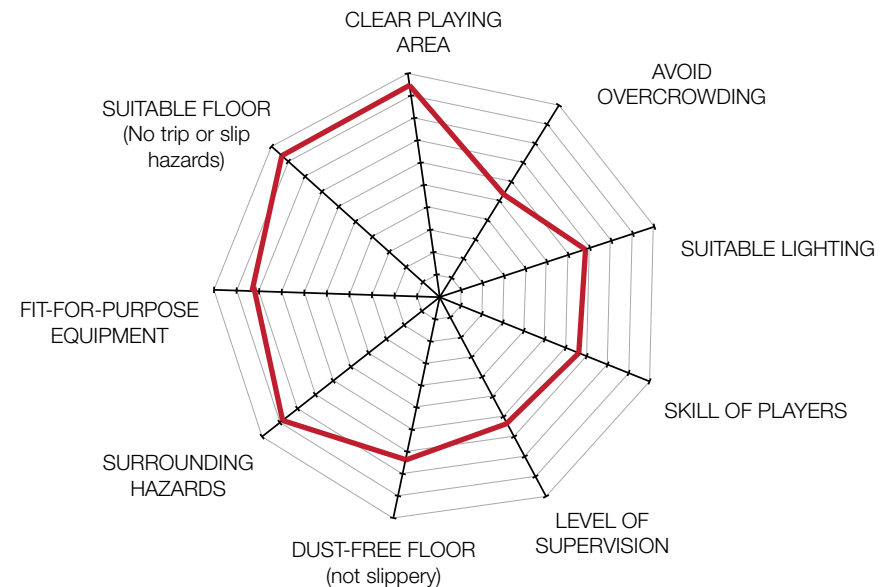

PUBLIC ACCESS DEFIBRILLATORS

In some instances, appropriate and proportionate contingency planning for medical emergency could be an important aspect of the infrastructure to enable more physical activity. As part of an overall risk assessment such consideration would provide an additional level of reassurance and comfort to user groups. As part of this approach, consideration should be given to providing public access defibrillators (PADs) in public spaces, community centres and activity spaces. They are sometimes called automated external defibrillators (AEDs).

AS PART OF AN OVERALL RISK ASSESSMENT, CONSIDERATION SHOULD BE GIVEN TO MEDICAL EMERGENCY PLANNING AND THE PROVISION OF PUBLIC ACCESS DEFIBRILLATORS.

FOR ADVICE ON HOW THEY ARE USED AND AVAILABLE FUNDING, SEE THE BRITISH HEART FOUNDATION AT:

<https://www.bhf.org.uk/how-you-can-help/how-to-save-a-life/defibrillators>



PHYSICAL ACTIVITIES COULD BE ACCOMMODATED IN A RANGE OF FACILITY TYPES

4.0 EXAMPLES

The following examples show typical multi-use configurations that could support physical activities.

EXAMPLE 1

ACTIVITY SPACE

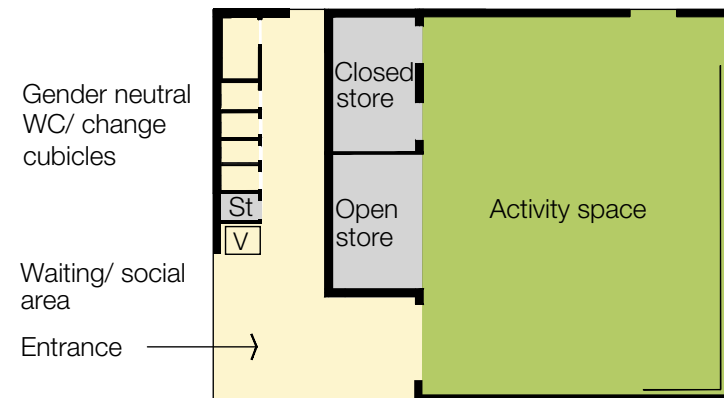

An activity space c 12 x 15 m could be incorporated into a new build or conversion project to support a range of physical activities. The inclusion of wall mirrors could enhance the space for use as an exercise studio. Adjacent open and closed storage areas increase flexibility of use.

The layout also shows an indicative entrance area with vending (v) and circulation to access gender neutral toilet and changing cubicles.

EXAMPLE 2

VILLAGE HALL

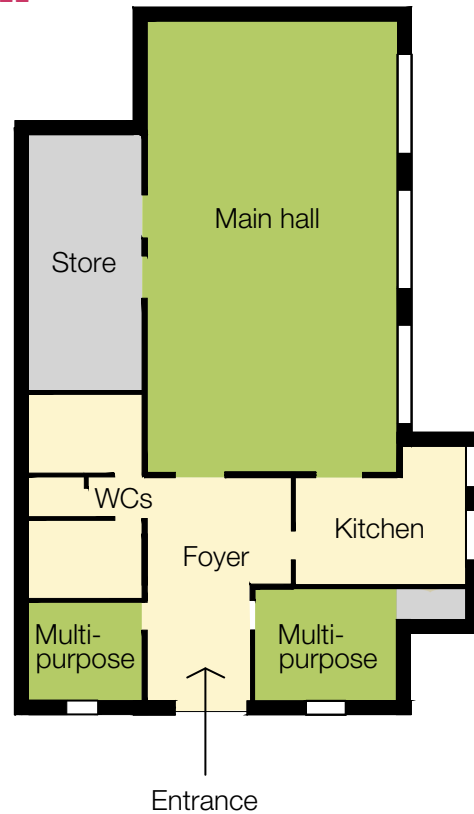

The main hall c 10 x 18 m could accommodate a wide range of community activities, as shown on the diagrams on page 11 and 13, for local groups and societies. The adjacent equipment and chair/table store (c 20% of the hall area) allows items to be easily set out for the particular activities.

Smaller multi-purpose rooms, kitchen, toilets and a reception area help to extend the flexibility and community value of the facility. The toilet areas only provide limited space for changing to reflect the preference of many users to wear casual clothing and shower at home.

EXAMPLE 3

SMALL COMMUNITY RECREATION CENTRE

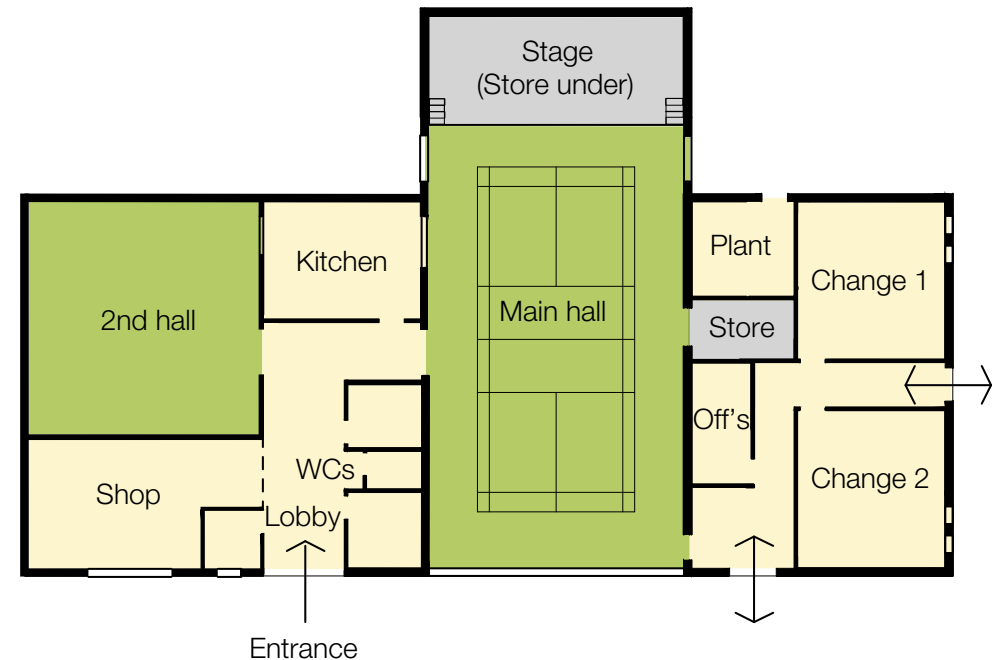

A similar 10 x 18 m main hall, with a smaller 9 x 9 m secondary hall that increases the range of physical and community activities that the building could support. The storage areas and kitchen have direct access from both halls to increase flexibility.

This example also includes changing room areas for outside pitches, social area, office and community shop.



ALTERNATIVE LANGUAGES AND FORMATS:

This document can be provided in alternative languages, or alternative formats such as large print, braille, tape and on disk upon request. Call the sport england switchboard on 08458 508 508 for more details.

ACKNOWLEDGEMENTS:

Sport England wishes to thank all the people who have contributed to this document including British Heart Foundation, Integra Modular Construction, Key, and Pozzoni Architects.

PREPARED BY:

Sport England, Robin Wilson Consulting, and Abacus Cost Management Ltd (Design Services).

USER GUIDE:

Before using this design guidance note for any specific projects all users should refer to the User Guide to understand when and how to use the guidance as well as understanding the limitations of use.

Click here for **'User Guide'**

Click here for current **'Design and Cost Guidance'**

ISSUE TRACKER:

001 – Initial Publication: April 2019

FURTHER INFORMATION:

To find out more about Sport England and to get the latest news and information about our various initiatives and programmes, please go to www.sportengland.org

DISCLAIMER:

This guidance note is provided for general information only. Sport England is not your adviser and any reliance you may place on this guidance is at your own risk. Neither Sport England, nor any contributor to the content of this guidance, shall be responsible for any loss or damage of any kind, which may arise from your use of or reliance on this guidance note. Care has been taken over the accuracy of the content of this note but Sport England cannot guarantee that the information is up to date or reflects all relevant legal requirements. The information and drawings contained in this guidance note are not site specific and therefore may not be suitable for your project, facility or event. We recommend that you obtain professional specialist technical and legal advice before taking, or refraining from, any action on the basis of information contained in this note. This guidance note is not intended for, and should not be used in connection with, any procurement activities, or for obtaining planning or other statutory approvals.



© Sport England, April 2019

Sport England

1st Floor
21 Bloomsbury Street
London
WC1B 3HF

Tel : +44 (0)8458 508 508